

SchuF FETTEROLF Worldwide

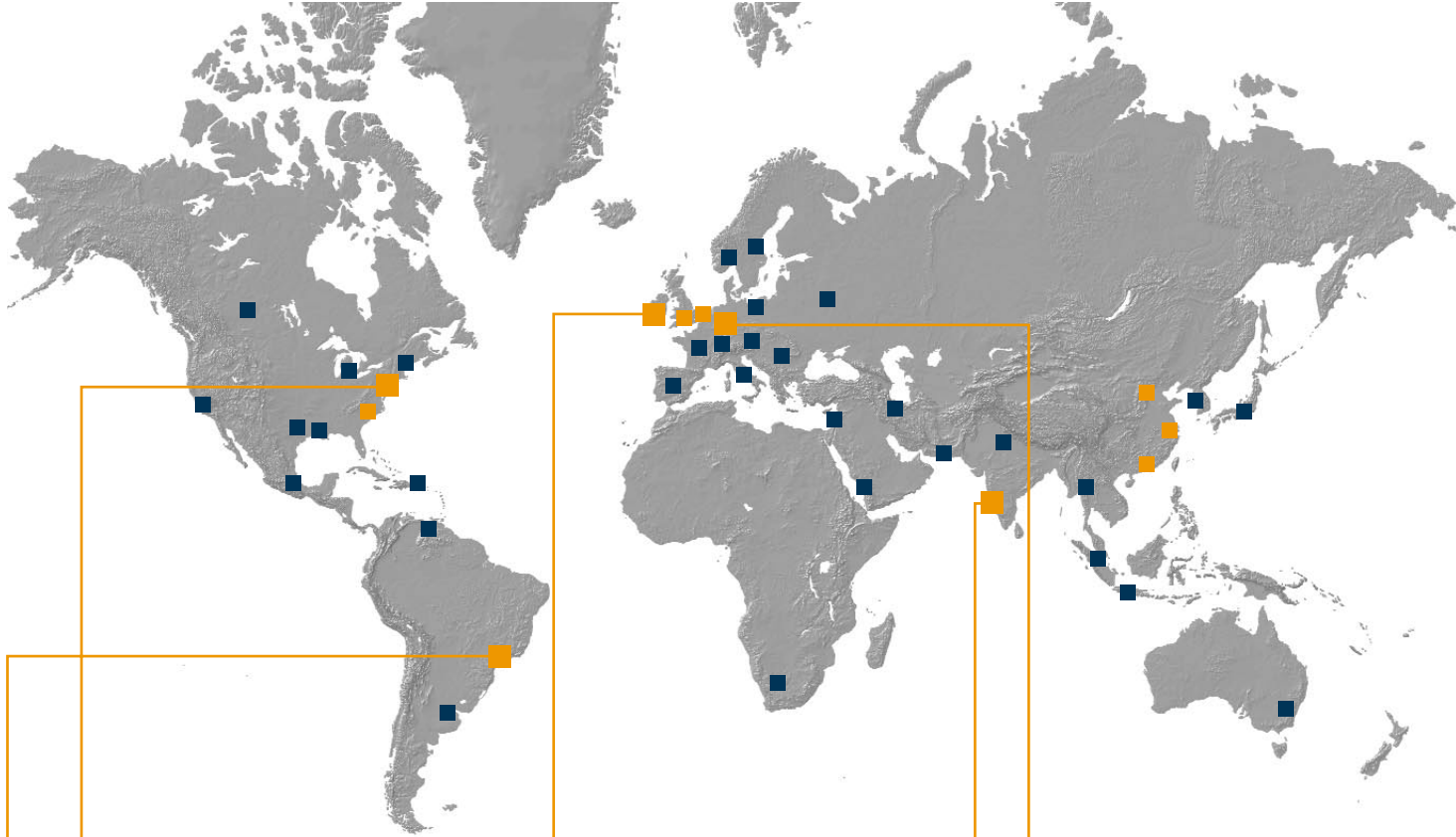

www.schuf.com · www.schuf.de

USA



Fetterolf Corporation, Inc.
 phone: +1 610 584-1500
 fax: +1 610 584-5904
 info@fetterolfvalves.com

SchuF (USA) Inc.
 phone: +1 843 8813345
 fax: +1 843 8816121
 sales@schuf.us

IRELAND



SchuF Valve Technology GmbH
 phone: +353 (0)21 4837000
 fax: +353 (0)21 4837030
 sales@schuf.ie

GERMANY



SchuF Chemieventile Vertriebs GmbH
 phone: +49 (0)6198 571100
 fax: +49 (0)6198 571200
 verkauf@schuf.de

BRAZIL



Fetterolf SchuF do Brazil Ltda
 phone: +55 19 39369090
 fax: +55 19 39353215
 fbvendas@fetterolf.com.br

Your Local Agent:

INDIA



SchuF Speciality Valves India Pvt. Ltd.
 phone: +91 421 2264600
 fax: +91 421 2362018
 sales@schuf-india.com

Cam-Set® & Stacey™ Line Blind Valves STECKBRILLENSYSTEM

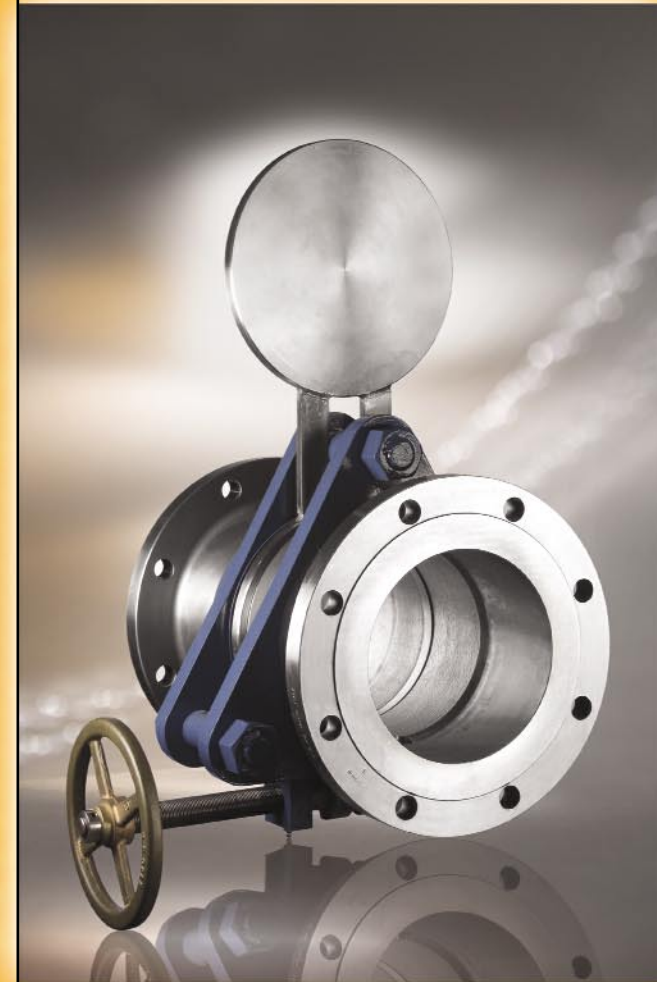

SchuF FETTEROLF

Safety First

Plant and personnel safety is a central theme for socially responsible and safety conscious companies. Following a series of fatal accidents across the globe, regulation now mandates certain minimum technical precautions in many industries. As a result the ability to isolate lines and ensure absolute downstream flow shut-off is essential.



Valve Limitation

Many different types of valves are used to isolate pipelines. However, valves can and do leak. Downstream valve leakage can occur without the knowledge of plant personnel as there is often no visual indication of failure. This scenario can at best lead to product waste or contamination; at worst to the escape of toxic substances or a potentially explosive fire hazard.

Line Blind Process

Line blinding is a process which ensures the total isolation or "blinding" of the downstream flow within a pipeline. It is a common procedure in industries that store, forward or process hazardous chemical or petrochemical substances or where the media may become unstable or potentially dangerous during part of a process. Line blinds often complement conventional valves used for isolation, in that they guarantee absolute and positive shut off to the downstream. Additionally, they provide a clear visual indication of their actual open or closed status.

Traditional Approach

Traditional line blinding methods such as inserting metal plates with a gasket between flanges assure safety, but are time consuming to open or close. Larger size blinds require numerous people or expensive equipment such as cranes to change.

Time Consuming

In the past, changing line blinds was considered an onerous, time consuming and often dangerous task.

The diagram below illustrates the time and manpower required to change a small size traditional line blind. Rotating the blind requires three men – two men to loosen the bolts and spread the line and the third to raise and rotate the heavy spectacle plate. It could take up to 4 hours to rotate one blind – particularly when nuts and bolts are rusted.

For larger size blinds above 12 inches the changing process can take between 4 and 12 hours by a team of up to 6 men. As such, traditional line blinding techniques represent a significant manpower, cost and safety factor.

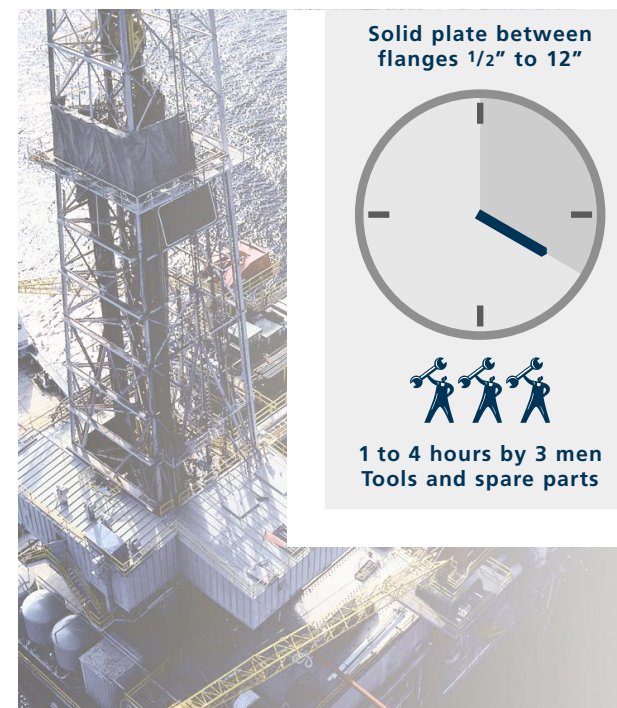

The Modern Alternative – The Cam-Set®

Modern line blind systems such as the SchuF Fetterolf Cam-Set® change the installation of the blind into a one man operation taking only minutes to complete. Downstream safety is assured. In all sizes, the Cam-Set® makes line blinding convenient, fast and safe.

Convenient, Fast, Safe

Convenient

Cam Sets are designed around an internal cam system such that the body flanges do not have to be spread and the adjacent piping does not have to move when the Cam-Set® spectacle plate is changed. This simple feature has enormous benefits, as piping movement can cause many problems – misalignment of the piping, piping support damage, and physical injury to the men trying to move heavy piping.

Fast and Cost Effective

The Cam-Set® is not only convenient but fast too. No bolts have to be loosened or removed – often a difficult job if the bolts are rusted.

The Cam-Set® in comparison can be changed in less than a minute for small sizes and up to 3 minutes for larger sizes.

SchuF Fetterolf line blind valves lead to significant cost and time savings.

In comparison to traditional smaller size line blinds to say twelve inches, the Cam-Set® can save between one and four hours per man per job.

For larger sized blinds the time saving can be anything from 4 to 12 hours per man per job.

In addition to the time savings there are no additional crane rental or usage fees required.

Cam-Set® – Key Features

- Absolute positive shut-off
- Fast change
- One man operation
- No flange or line spreading
- No special equipment required
- Conforms / exceeds ASME B16.5 and API 590
- Unique safety features



Cam-Set® DN 150 (6"), ASME 150#

Materially Safe

The Cam-Set® incorporates many material and construction safety features. They are built to meet or exceed ASME B16.5 standards. The thickness of the Cam-Set® spectacle plate is equal to or greater than that required by API 590 (ASME B16.48).

The tensile bolting area of the Cam-Set® is also equal to or greater than the tensile bolting area used in the flanges.

All of the body bolts are tack welded so that they cannot be inadvertently removed or loosened.

The SchuF Fetterolf Cam-Set® is easy to operate and safe – by design.

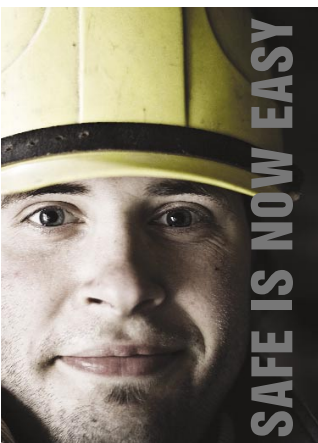

Operation

How the Cam-Set® works

The internal cam system is actuated via a single screw (or hand wheel) which is perpendicular to the axis of the pipe. When the screw is rotated a movable inclined plane slides against a fixed inclined plane, moving the seal carrier away from the spectacle plate, thus freeing it to be moved to a new position.

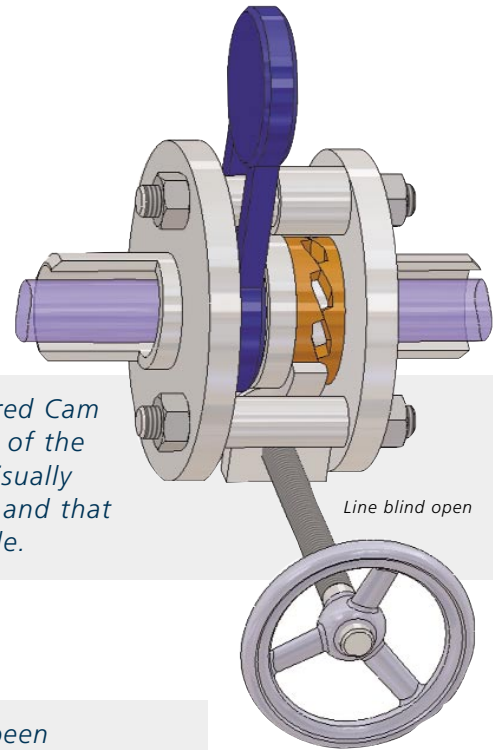

1) In this picture, the orange coloured Cam mechanism is closed. The solid part of the spectacle plate is above the pipe, visually indicating that the pipeline is open and that full flow through the line is available.

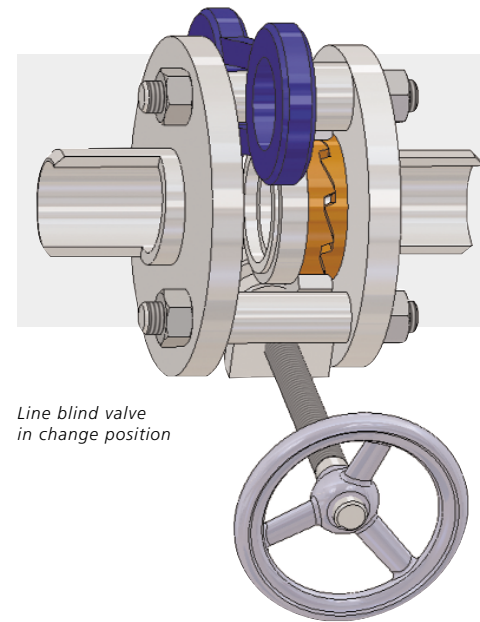

2) Once the pipeline has been depressurised and drained, the Cam-Set® can be operated. In this picture the Cam mechanism is retracted. The hand wheel has been rotated counter clock-wise to achieve this. The spectacle plate is between the open and closed position.

Line blind valve in change position

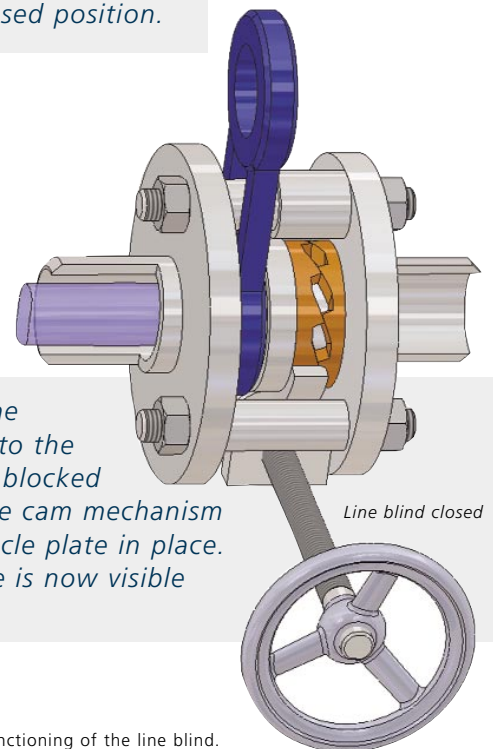

3) In this picture the solid part of the spectacle plate has been inserted into the pipeline and flow to downstream is blocked by the line blind valve. Note that the cam mechanism is extended, thus locking the spectacle plate in place. The open part of the spectacle plate is now visible indicating that the line is blocked.

Note: the above drawings are presented in a cut away format in order to illustrate the internal functioning of the line blind.

Cam-Set® Options

The Cam-Set® comes with many options to match almost every requirement or operating environment. This includes a wide variety of seals and seal materials.

All seals in a Cam-Set® line blind may be replaced without removing the line blind from the piping system.

The sealing rings themselves are protected within the body of the blind, but can also be placed in the spectacle plate should regular inspection be required.



Cam-Set® DN 100 (4"), ASME 300#

Corrosive Environment

The Maritime industry is a good example of line blind usage in a corrosive environment. When used aboard a ship or tanker, a Sermetel coating is frequently used to protect any carbon steel parts from corrosion due to the salt air atmosphere. Likewise the stem is in a high alloy corrosive resistant material, the hand wheel is bronze and all bolting or wetted parts are in stainless steel.

Larger Sizes

As the size of the line blind increases above 12 inches and up to 48 inches or greater, the job of swinging the spectacle plate can be cumbersome due to the offset weight. In these instances a special **counterweight** can be added to the blind which maintains the easy and safe "One Man Operation" benefits of the Cam-Set® for larger sizes.

Line blinding using the Cam-Set® can be achieved by one man on **one side** of the pipeline, without the necessity of multiple spreader bolts or a crane.



Cam-Set® DN 500 (20"), ASME 150# with spectacle plate support

Coupled Piping

The Cam-Set® can be used on close coupled piping such as tank farms, off shore platforms or ships and barges.

High Temperature

A special high temperature line blind for application environments up to 538°C / 1000°F is also available.

Other options include:

- Locking devices
- Spectacle plate covers
- Special coatings
- Drain, purge and sampling valve combinations
- Roller support for spectacle plates
- Sealing ring in spectacle plate
- Dual and triple sealing rings
- Pneumatic or hydraulic actuation
- Counterweights

Drawing and Dimension Table for Cam-Set® (ASME 150#)

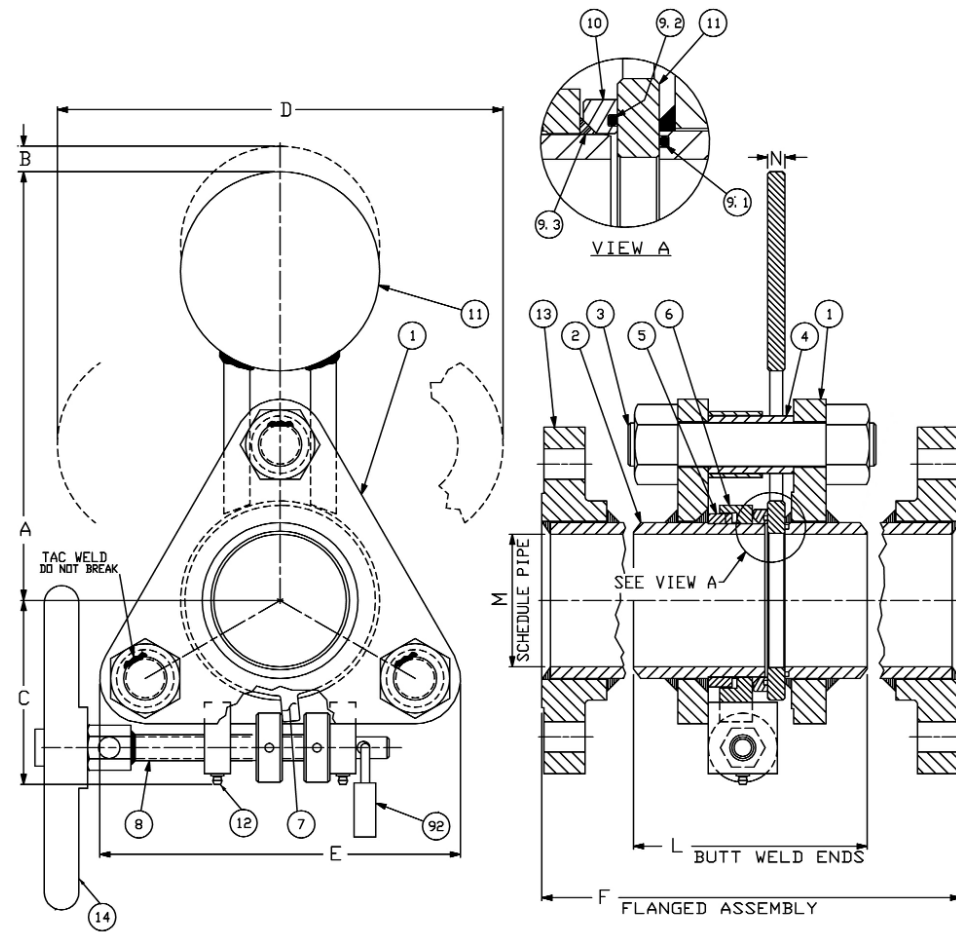

Cam-Set® front view

Cam-Set® side view

Nr	Description
1	Body Flange
2	Body Pipe
3	Body Bolts
4	Body Bolt Spacer
5	CAMS
6	Sealing Actuator
7	Actuator Lever
8	Actuator Screw Assembly
9.1	Seal Ring
9.2	Seal Ring
9.3	Seal Ring
10	Seal Carrier
11	Spectacle Plate Assembly
12	Grease Fitting
13	Flange 150 ASME Standard
14	Hand Wheel
92	Lock

Size	mm:	A	B	C	D	E	F	L	M	N
DN 25 / 1"		127	13	64	159	127	178	165	80	13
DN 40 / 1 1/2"		159	16	76	197	152	190	178	80	13
DN 50 / 2"		178	10	83	229	165	203	190	80	13
DN 80 / 3"		229	19	102	289	203	222	203	80	13
DN 100 / 4"		279	19	127	356	235	248	229	80	13
DN 125 / 5"		349	25	140	438	298	292	267	80	16
DN 150 / 6"		394	25	171	495	337	292	267	80	16
DN 200 / 8"		502	41	200	635	400	317	n/a	80	16
DN 250 / 10"		654	44	229	816	483	356	330	60	16
DN 300 / 12"		762	57	279	953	591	381	356	80S	22
DN 350 / 14"		800	57	279	1003	625	406	381	xH	22
DN 400 / 16"		908	89	330	1137	711	432	406	60	22
DN 450 / 18"		975	76	368	1232	813	686	660	60	25
DN 500 / 20"		1111	73	413	1403	857	711	686	60	25
DN 600 / 24"		1245	83	470	1581	978	838	813	60	38

All dimensions above are in mm for ASME class 150# unless otherwise stated. Alternative Cam-Set® models are available on request.

Cam-Set® Line Blind Specifications

Description	Standard Cam-Set®	Optional Cam-Set®
Size	DN 10-15 (1/2") to DN 1200 (48")	Larger on request
Pressure class	ASME 150#, 300#, 600#	to ASME 1500# or higher on request
Body material	Carbon steel	316 stainless steel; others on request
Spectacle Plate	Stainless steel	Duplex, Hastelloy, Alloy 20, Inconel, Nickel, Monel & Titanium
Stem	Carbon steel	Monel
Bolting	Carbon steel	316 stainless steel; others on request
Sealing Ring	Viton, Buna-N	Teflon, Nordel, Chemraz, Kalrez and others depending on application
Temperature	232°C / 450°F	up to 538°C / 1000°F
Pipe Connection	Butt weld end	Flanged
Drain/Purge Connection	n/a	Line drain, purge or sampling valve combinations are possible
Coatings	Standard paint	Epoxy, Polyurethane, Sermetel, Ceramic and many others
Counterweight	n/a	Yes; recommended on large sizes
Locking device	n/a	Yes
Standards/Certification	ASME, DIN, CRN, ISO, PED	TÜV, NACE, US Navy
Actuation	Hex nut	Hand wheel, pneumatic, hydraulic

Engineering Standards

ASME Standard	Description
B16.5	Pipe flanges and flanged fittings
B16.34	Valves - flanged, threaded and welding end
B31.1	Power piping
ASTM F1020-86	Line Blind Valves for Marine Applications
ASME B & PV Code	Description (Boiler & Pressure Vessel Code)
Section 2	Material
Section 8	Rules for construction of pressure vessels
Section 9	Welding and brazing qualifications
API Standard	Description
API 590 (now ASME 16.48)	Steel Line Blanks for Refining
API 598	Valve inspection and testing
API 2217	Guidelines for confined space work in the Petroleum Industry
Others	Description
ISO 9001:2000	Quality management system
NACE MR 0175	Sulfide stress cracking and stress corrosion



Cam-Set® DN 150 (6"), ASME 150#, side view

Stacey™ Line Blind System

The Stacey is a modern line spreading line blind system. It has a number of advantages over conventional blind plates such as ease of use, one to two man operation, absolute shut off, and is relatively quick to use. In this respect the Stacey can be changed in five to ten minutes depending on size and can break any crust build-up in or on the blind.

Stacey spectacle blinds are available in **all** ASME pressure ratings, a wide range of sizes



Stacey DN 850 (34") with counterweight

and a wide range of materials. The multiple bolts expand the list of possible sealing materials for service temperatures from cryogenic to elevated. They are a viable alternative to the Cam-Set® when flexibility and ease of use are less important.

Operation

With the Stacey blind 3, 5, 7 or 9 bolts (depending on size) are loosened in even quarter turns for one to two revolutions, automatically spreading the body flanges apart far enough to rotate the spectacle plate to its desired position – fully open or closed.

Retighten the bolts evenly and the change is complete. Bolt heads are drilled to receive a short piece of steel bar or pipe – no special tools are required.

Applications

The Stacey is ideal for certain types of applications where the line blind must be both large and have a high pressure rating (ASME 900 and above). Similarly several applications that require the line blind to operate in a severe or powdery environment, such as in the cement or alumina industry, are better served by the Stacey.

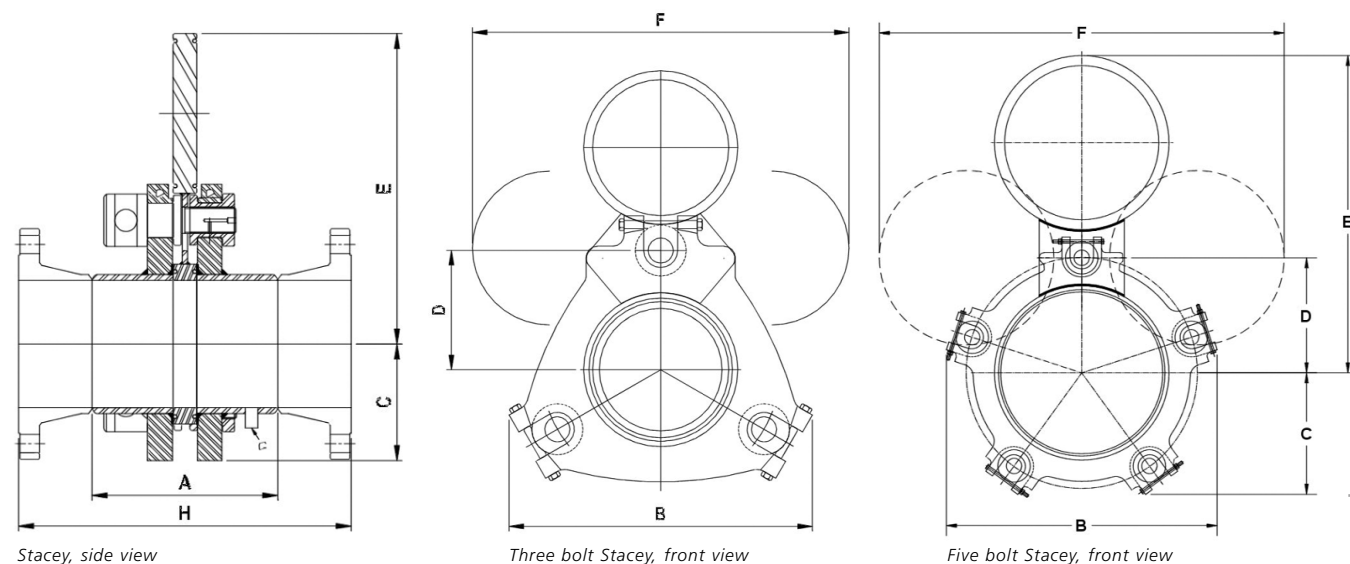

Stacey, side view

Three bolt Stacey, front view

Five bolt Stacey, front view

Dimension Table for Stacey™

mm	Class	DN 25 / 1"	DN 40 / 1 1/2"	DN 50 / 2"	DN 65 / 2 1/2"	DN 80 / 3"	DN 100 / 4"	DN 125 / 5"	DN 150 / 6"
A	150#	165	178	178	203	203	203	229	229
	300#	165	178	178	222	222	241	279	279
	600#	191	210	210	241	241	273	292	292
B	150#	197	219	219	241	241	305	381	381
	300#	197	219	219	241	241	343	406	406
	600#	216	254	254	305	305	406	457	457
C	150#	76	76	76	102	102	114	152	152
	300#	76	76	76	102	102	130	152	152
	600#	89	102	102	121	121	140	165	165
D	150#	67	76	76	92	92	114	149	149
	300#	67	76	76	92	92	121	152	152
	600#	73	79	79	102	102	127	171	171
E	150#	152	197	197	241	241	298	381	381
	300#	152	197	197	241	241	298	381	381
	600#	165	191	191	248	248	330	445	445
F	150#	178	241	241	295	295	352	464	464
	300#	178	241	241	295	295	365	473	473
	600#	203	248	248	318	318	406	546	546
G	Drains	n/a	n/a	13	13	13	13	19	19
H	150#	273	302	302	340	340	352	403	403
	300#	286	311	311	378	378	410	473	473
	600#	311	346	352	403	403	457	514	514

mm	Class	DN 200 / 8"	DN 250 / 10"	DN 300 / 12"	DN 350 / 14"	DN 400 / 16"	DN 450 / 18"	DN 500 / 20"	DN 600 / 24"
A	150#	254	254	279	305	381	432	483	610
	300#	368	381	406	419	432	-	-	-
	600#	381	406	-	-	-	-	-	-
B	150#	419	508	565	635	711	787	851	1.067
	300#	464	559	622	699	787	-	-	-
	600#	521	610	-	-	-	-	-	-
C	150#	165	203	229	254	324	356	387	479
	300#	171	248	305	318	356	-	-	-
	600#	229	267	-	-	-	-	-	-
D	150#	171	213	244	270	298	330	359	454
	300#	178	213	251	273	305	-	-	-
	600#	191	229	-	-	-	-	-	-
E	150#	451	552	648	737	826	914	1003	1245
	300#	476	575	673	737	838	-	-	-
	600#	508	622	-	-	-	-	-	-
F	150#	578	711	832	927	1067	1168	1270	1581
	300#	597	737	851	940	1067	-	-	-
	600#	635	787	-	-	-	-	-	-
G	Drains	19	25	25	25	25	25	25	25
H	150#	451	451	502	552	629	705	762	905
	300#	587	610	660	699	718	-	-	-
	600#	641	705	-	-	-	-	-	-

All dimensions are in mm unless otherwise stated. Dimensions for other Stacey models are available on request.

Industry Case Studies for Cam-Set® and Stacey™

SchuF Fetterolf Cam-Set® and Stacey line blind valves are commonly used in the most critical applications: aboard tankers product cross contamination or accidental overboard discharge assumes the proportions of a disaster; in chemical and petrochemical plants, refineries and tank storage farms; and where vessel entry is a problem. Power generating plants install them upstream of equipment which will require repairs. Other important users include steel mills, cement manufacturing plants, and the pulp and paper industry.

Refinery

Petrobras, the leading state refinery in Brazil, uses the Cam-Set® and Stacey line blind system extensively.

They are used in several process areas in the refinery including:

- Gas flare applications
- Hydrocracking units
- Catalytic cracking unit
- Delayed coking
- Storage tanks

Over 200 SchuF Fetterolf line blind valves have been installed. The refinery enjoys a strong reputation for good maintenance and safety procedures.

Maritime

GATX Terminal Corporation is one of the worlds leading port, terminal, rail and ship operators. At their Philadelphia and New Jersey sea terminals, they have replaced all traditional blinds with the Cam-Set®. They are used on 16" lines to ensure total isolation between different tanks in order to prevent product cross contamination. Traditional line blinds could not be used as line spreading dented and buckled the tank walls.

The customer has commented: "With the Cam-Set®, it is a cinch to quickly change from closed to open by turning only one bolt and not moving any piping!".

The special maritime Cam-Set® has been installed by many marine and shipping companies including: Chevron Marine, Texaco (Oil and Marine), Exxon, Pratt & Whitney, Emarat, BP and Ocean Ships to name a few.

Offshore

SchuF Fetterolf has recently been chosen for several offshore projects. Used around compressors on oil platforms and oil refining and processing ships, the Cam-Set® and Stacey are ideal due to their ability to provide higher pressure ratings and/or large sizes up to 54". The high quality construction and safety standards of the Cam-Set® and Stacey are greatly respected in this industry, especially as they are easy to operate in stormy weather.

Steel Industry

A rugged sturdy design and absolute safe shut off are critical factors for the steel industry. Line blinds installed in and around coke oven gas and blast furnace fuel lines have to be absolutely secure despite tremendous pressure on the blinds.

The SchuF Fetterolf Cam-Set® is ideal for these applications due to its attention to safety factors. The spectacle plate thickness is specified to exceed API standards, there are two O-rings sealing the plate and the body bolts are tack welded to ensure that they are not removed due to operator error. These features have led steel mill customers such as Kobe Steel USA, Corus, AK Steel Corporation, Arcelor Mittal and others to choose SchuF Fetterolf.

SchuF Fetterolf Valve Portfolio

SchuF Fetterolf has delivered over one million valves during its almost 100 year history to a wide variety of industries in over 50 countries worldwide.

Headquartered near Frankfurt in Germany, the company has additional design and manufacturing centres in Brazil, India, Ireland and the United States.

The SchuF group has sales and agent offices covering almost every country in the world.

We manufacture valve products that control, isolate, divert, and sample liquids, gases, powders, and slurries. Our product range of engineered, customised valves includes:

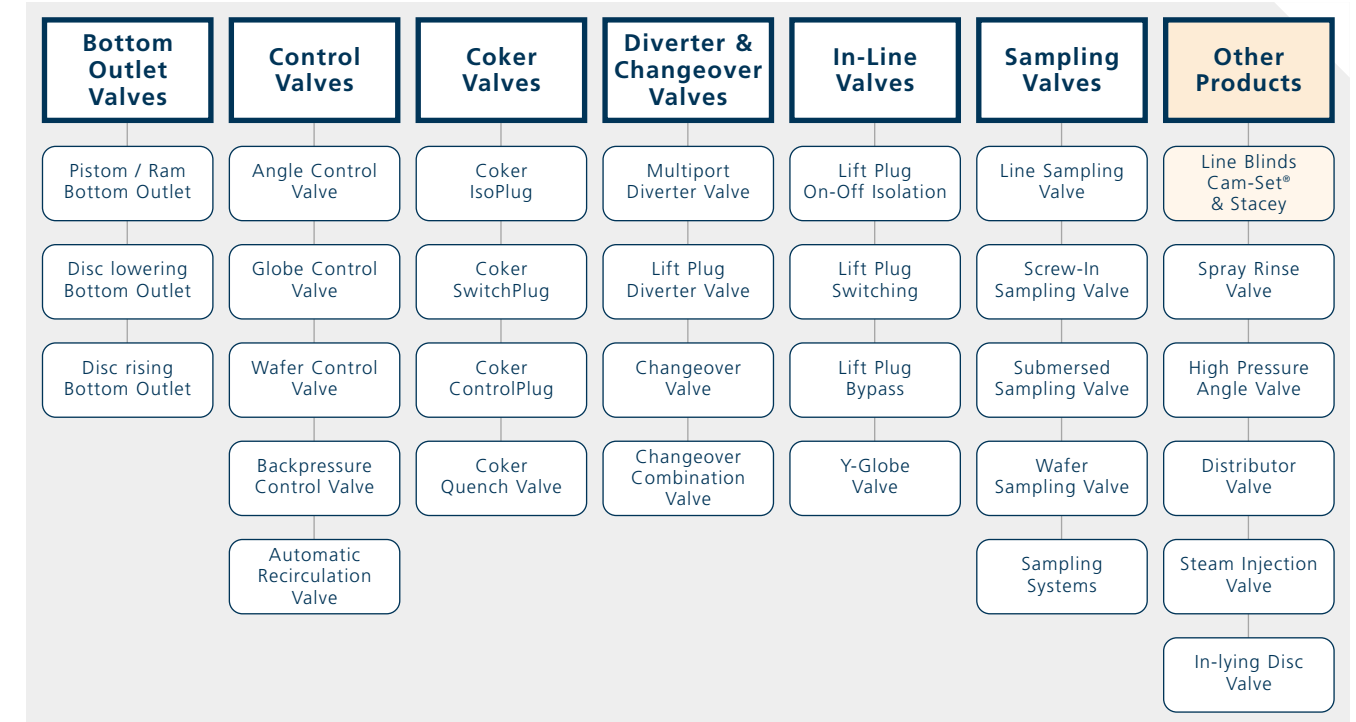

Sample Cam-Set® and Stacey™ Client List:

- | | | |
|--------------------------|-----------------------------|--------------------------|
| ■ Alcoa | ■ GATX Terminals | ■ Procter & Gamble |
| ■ Alunorte | ■ General Electric | ■ Pfizer |
| ■ BASF | ■ Henkel Chemicals | ■ Rhone Poulenc |
| ■ BP | ■ Hyundai Ship Building | ■ Sandoz |
| ■ Celanese | ■ Keppel Marine | ■ Shell Oil |
| ■ Chevron Marine | ■ Merck & Co. | ■ Texaco Oil & Marine |
| ■ Degussa | ■ Nestlé | ■ Toyo USA |
| ■ Dow Chemical | ■ Norsk Hydro | ■ US Navy |
| ■ Du Pont | ■ Northrop-Grumman Shipyard | ■ Venezuela Cement |
| ■ Exxon Oil & Chemical | ■ Petrobras Brazil | ■ Wallen Ship Management |
| ■ Fluor | | ■ Zeneca |
| ■ Formosa Petrochemicals | | |



Cam-Set® DN 150 (6"), ASME 150#

SAFE IS NOW FAST