

# 1471

**Gate valves**  
**Flexible wedge**  
**Bellow sealed**  
**PN 40-63 DN 50-300**

**Design**  
 Acc. to DIN 3352

**Top part**  
 Outside screw  
 Non-rising handwheel  
 Rising stem

**Stem sealing**  
 Bellow with additional  
 Stuffing box

**Obturator**  
 Flexible wedge

**Body seat**  
 Integral seats

**Valve ends**  
 Flanges acc. to  
 EN 1092-1 (DIN 2501  
 Part 1)

**Requirements and tests**  
 Acc. to DIN 3352 Part 1

**Marking**  
 Nominal size DN  
 Nominal pressure PN  
 Body material  
 Manufacturer brand

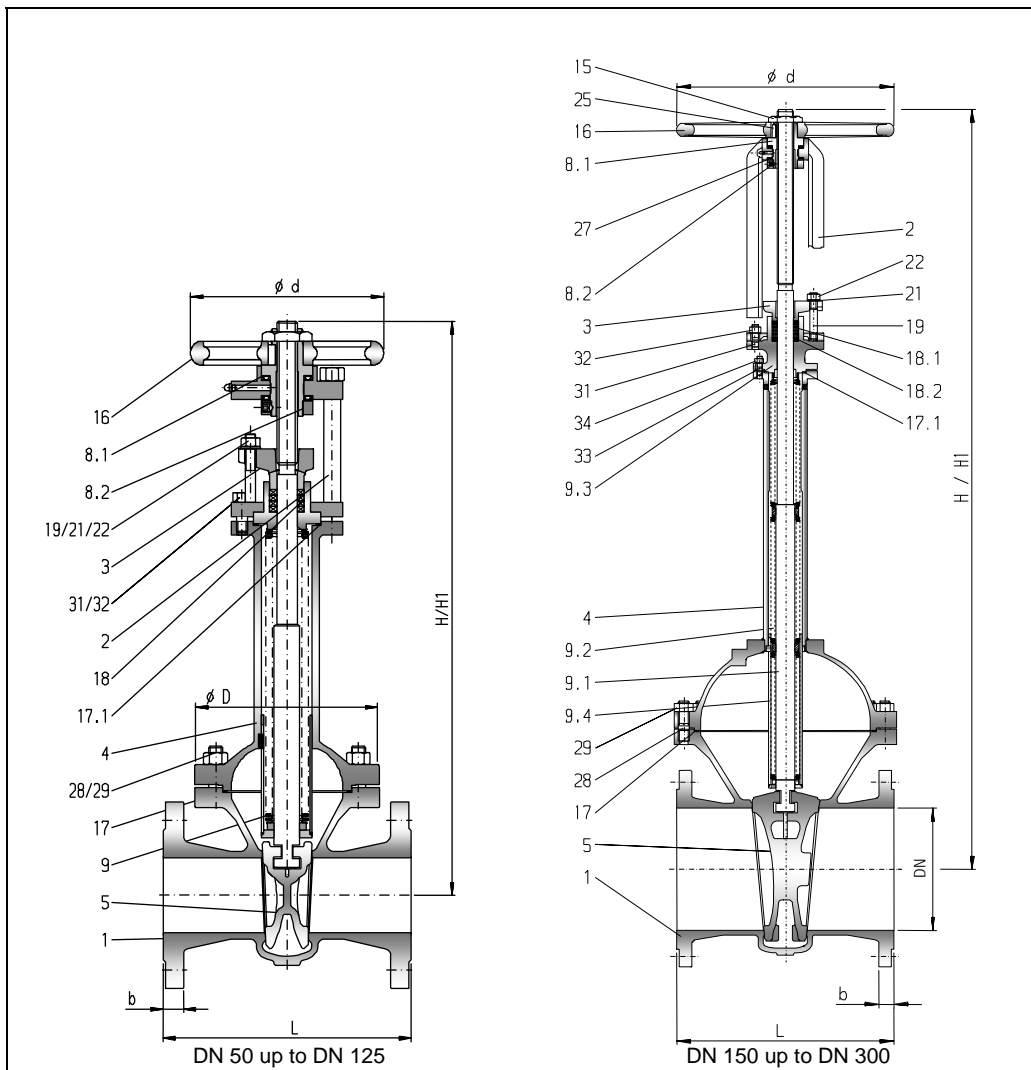

Pos.	Denomination	Material		Pos.	Denomination	Material	
		1.4308	1.4408			1.4308	1.4408
1	Body	1.4308	1.4408	17	Gasket	1.4541 /	1.4571 /
2	Yoke	1.4308	1.4408		(grooved)	Graphite	Graphite
3	Gland	1.4541	1.4571	18	Packing	Graphite	Graphite
4	Bonnet	1.4308 /	1.4408 /	19	Stud bolt	A2-70	A4-70
		1.4541	1.4571	21	Washer	1.4541	1.4571
5	Wedge	1.4308	1.4408	22	Hex. Nut	A2	A4
8.1	Sleeve	0.7040	0.7040	27	Bearing	Cr.-steel	Cr.-steel
8.2	Threaded ring	1.4021	1.4021	28	Stud bolt	A2-70	A4-70
9.1	Stem	1.4541	1.4571	29	Hex. Nut	A2	A4
9.2	Bellow	1.4571	1.4571	31	Stud bolt	A2-70	A4-70
9.3	Gland housing	1.4541	1.4571	32	Hex. Nut	A2	A4
9.4	Guide tube	1.4541	1.4571	33	Stud bolt	A2-70	A4-70
15	Retaining nut	Steel, zinc-coated		34	Hex. nut	A2	A4
16	Handwheel	Steel	Steel				

<sup>1</sup> further materials are shown in the technical part

**Face-to-face dimensions acc. to EN 558-1 series 26 (DIN 3202-F7)**

DN	50	65	80	100	125	150	200	250	300
L	250	290	310	350	400	450	550	650	750
PN 40	H	520		630	770		1.175	1.340	
	H1	580		735	890		1.345	1.560	
	Ø d	200		250	320		400	400	500
	Ø D	178		215	215		325	395	445
	b	20		24	24		28	34	38
kg									47 <sup>2</sup>
PN 63	H	575		720					
	H1	640		820					
	Ø d	200		225	320				
	Ø D	180		230	270				
	b	26		28	30				
kg									

<sup>2</sup> reinforced against DIN/EN

**Pressure/Temperature ratings in bar g at Temperature in °C**

Material	PN	50°C	120°C	150°C	200°C	250°C	300°C						
»1.4308« GX5CrNi19-10 EN 10213	40	40,0	30,8	26,8	22,8	21,0	19,4						
	63	63,0	48,6	42,3	36,0	33,1	30,6						
»1.4408« GX6CrNiMo18-10-2 EN 10213	40	40,0	33,1	29,0	25,1	22,8	20,5						
	63	63,0	52,2	45,7	39,6	36,0	32,4						

**Modifications**

Position indicator  
Butt-welding ends  
Pressure relief  
By-pass tube

**Additional equipment**

Chain wheel  
Stem extension  
Gear  
Electric actuator

**Installation**

Piping is to be in such a manner that injurious thrust and bending forces are kept away from the valve casings. Gate valves are usually installed with vertical stem position. Gate valves can also be installed in pipelines with changing flow directions. If in the closed position the medium between the obturator and the middle area of the body can be heated up, the user has to check if a cavity pressure relief must be used. In this case e.g. a relief valve will be installed via tube to the inlet side of the gate valve (defined flow direction). When turning the handwheel it is not allowed to use additional levers.