

1452

Gate valves Double disk type

PN 40-160 DN 50-600

Design

Acc. to DIN 3352

Top part

Outside screw
Non-rising handwheel
Rising stem
Up to DN 125 one-piece bonnet

Obturator

Double disk

Body seat

Integral seats

Valve ends

Flanges acc. to
EN 1092-1 (DIN 2501
Part 1)

Requirements and tests

Acc. to DIN 3352 Part 1

Marking

Nominal size DN
Nominal pressure PN
Body material
Manufacturer brand

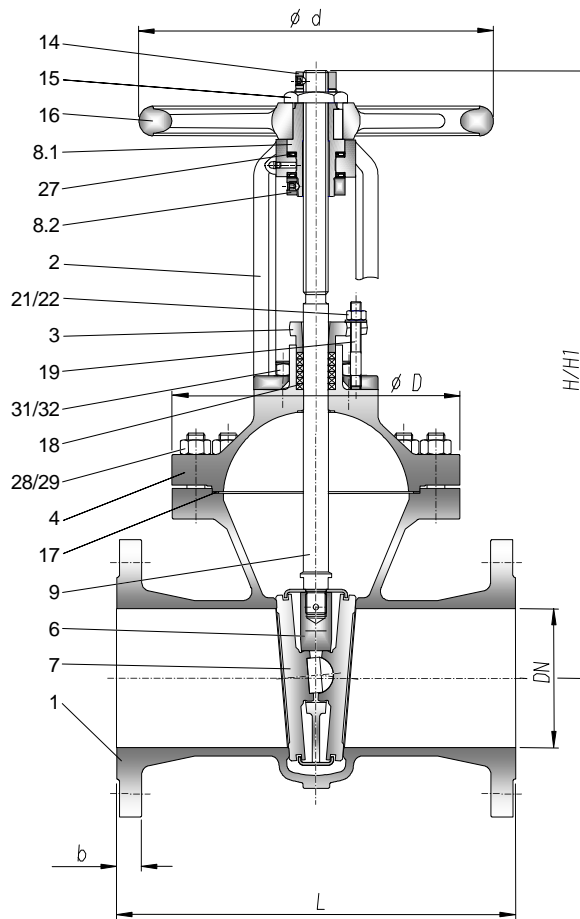

Pos.	Denomination	Material		Pos.	Denomination	Material	
		1.4308	1.4408			1.4308	1.4408
1	Body	1.4308	1.4408	17	Gasket	1.4541 /	1.4571 /
2	Yoke	1.4308	1.4408		(grooved)	Graphite	Graphite
3	Gland	1.4541	1.4571	18	Packing	Graphite	Graphite
4	Bonnet	1.4308	1.4408	19	Stud bolt	A2-70	A4-70
6	Support	1.4308	1.4408	21	Washer	1.4541	1.4571
7	Sealing plates	1.4541	1.4571	22	Hex. Nut	A2	A4
8.1	Sleeve	0.7040	0.7040	27	Bearing	Cr.-steel	Cr.-steel
8.2	Threaded ring	1.4541	1.4571	28	Stud bolt	A2-70	A4-70
9	Stem	1.4541	1.4571	29	Hex. Nut	A2	A4
14	Stroke limiter	1.4021	1.4021	31	Stud bolt	A2-70	A4-70
15	Retaining nut	Steel, zinc-coated		32	Hex. nut	A2	A4
16	Handwheel	Steel	Steel				

¹ further materials are shown in the technical part

Face-to-face dimensions acc. to EN 558-1 series 26 (DIN 3202-F7)

DN	50	65	80	100	125	150	200	250	300	350	400	500	600
L	250	290	310	350	400	450	550	650	750	850	950	1150	1350
PN 40	H	340	380	425	495	620	670	825	970	1160	1285	1495	2010
	H1	405	460	525	615	765	845	1050	1245	1490	1660	1930	2325
	ϕd	200	225	225	320	360	400	400	500	640	640	800	1000
	ϕD	178	185	215	215	255	325	395	445	515	640	715	835
	b	20	22	24	24	26	28	34	38	47 ²	47 ²	60 ²	72 ²
kg													
PN 63	H	340	380	425	495	620	690	905	1035	1210	1320	1540	1870
	H1	405	460	525	615	765	865	1130	1315	1445	1695	1975	2405
	ϕd	200	225	225	320	360	400	500	640	720	720	800	1000
	ϕD	180	190	230	270	300	345	425	485	580	690	725	835
	b	26	26	28	30	34	36	42	46	52	56	60	70 ²
kg													

² reinforced against DIN/EN

Face-to-face dimensions acc. to EN 558-1 series 26 (DIN 3202-F7)

DN	50	65	80	100	125	150	200	250	300	350	400	500	600
L	250		310	350		450	550	650	750		950	1150	
PN 100	H	480	510	590		775	935	1145	1240		1570	1870	
	H1	545	610	710		995	1165	1435	1585		2005	2405	
	Ø d	320	320	400		500	640	720	800		1000	1000	
	Ø D	200	240	270		340	435	530	590		725	835	
	b	30	36	40		44	52	60	68		83 ²	70 ²	
kg													

Face-to-face dimensions acc. to DIN 3202-F8

DN	50	65	80	100	125	150	200	250	300	350	400	500	600
L	300		390	450		600	750						
PN 160	H	438	544	575		777	886						
	H1	497	636	688		947	1106						
	Ø d	225	400	400		500	600						
	Ø D	215	275	318		415	525						
	b	30	36	40		50	60						
kg													

² reinforced against DIN/EN

Pressure/Temperature ratings in bar g at Temperature in °C

Material	PN	50°C	120°C	150°C	200°C	250°C	300°C						
»1.4308« GX5CrNi19-10 EN 10213	40	40,0	30,8	26,8	22,8	21,0	19,4						
	63	63,0	48,6	42,3	36,0	33,1	30,6						
	100	100,0	77,1	67,1	57,1	52,5	48,5						
	160	160,0	123,4	107,4	91,4	84,1	77,7						
»1.4408« GX6CrNiMo18-10-2 EN 10213	40	40,0	33,1	29,0	25,1	22,8	20,5						
	63	63,0	52,2	45,7	39,6	36,0	32,4						
	100	100,0	82,8	72,5	62,8	57,1	51,4						
	160	160,0	132,5	116,1	100,5	91,4	82,2						

Modifications

Position indicator
Extended bonnet
Butt-welding ends
Pressure relief
By-pass tube
Spring loaded stuffing box
Heating jacket

Additional equipment

Chain wheel
Stem extension
Gear
Electric actuator

Installation

Piping is to be in such a manner that injurious thrust and bending forces are kept away from the valve casings. Gate valves are usually installed with vertical stem position. Gate valves can also be installed in pipelines with changing flow directions. If in the closed position the medium between the obturator and the middle area of the body can be heated up, the user has to check if a cavity pressure relief must be used. In this case e.g. a relief valve will be installed via tube to the inlet side of the gate valve (defined flow direction).
When turning the handwheel it is not allowed to use additional levers.

06/2008 - 1452.400-700.202/205e – Subject to change without notice